

Mathematics

Stage 9

Paper 1

2024

Cambridge Lower Secondary Progression Test

Name

Class

Date

1 hour

Additional materials: Geometrical instruments
Tracing paper (optional)

INSTRUCTIONS

- Answer **all** questions.
- Write your answer to each question in the space provided.
- You should show all your working on the question paper.
- You are **not** allowed to use a calculator.

INFORMATION

- The total mark for this paper is 50.
- The number of marks for each question or part question is shown in brackets [].

- 1 The diagram shows a quadrilateral with the exterior angles marked.

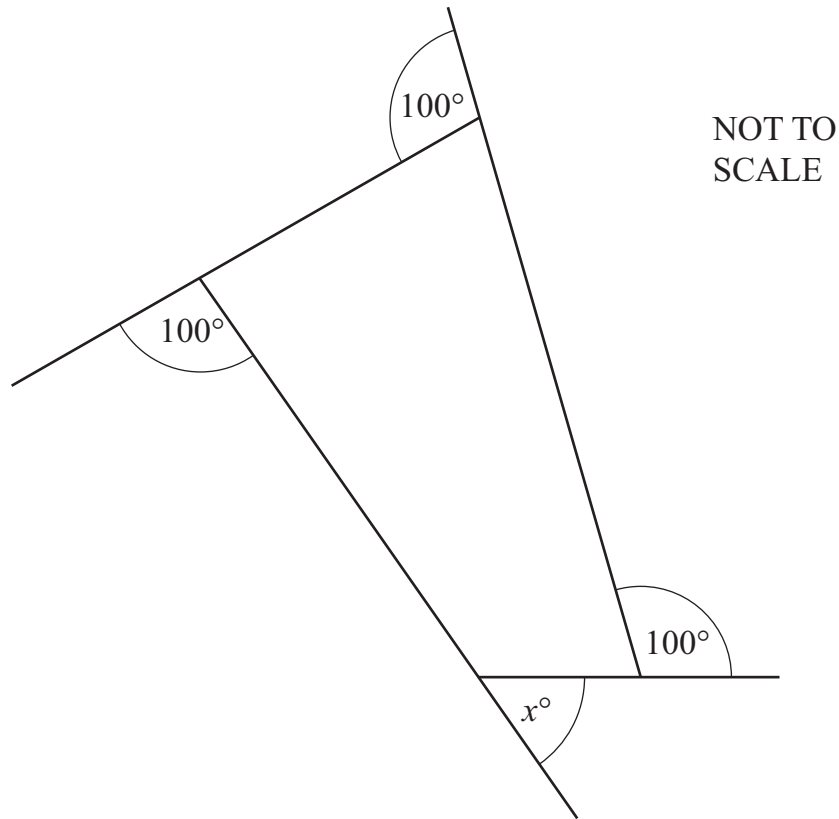

Calculate the value of x .

$x = \dots\dots\dots$ [1]

- 2 Here are some calculations.

-9×7

$-8 \div (-4)$

$(-3)^2$

$12 \div (-3)$

Write each calculation in the correct column in the table.

One has been done for you.

Answer is positive	Answer is negative
	-9×7

[1]

- 3 The term-to-term rule of a sequence is **square and then add 2**
The 1st term of the sequence is 3

Find the 2nd term of the sequence.

..... [1]

- 4 Draw a ring around the number that is rational.

$\sqrt{2}$

$\sqrt{4}$

$\sqrt{6}$

$\sqrt{8}$

[1]

- 5 Show that the area of the trapezium is smaller than the area of the square.

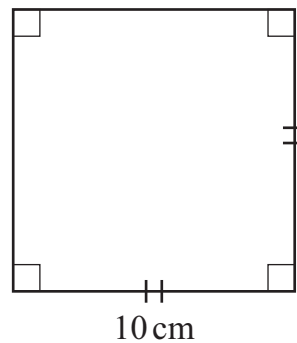
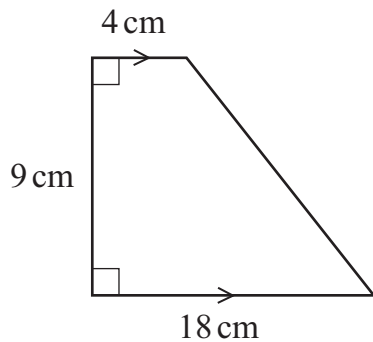

NOT TO
SCALE

[2]

- 6 The value of x is an integer.

$$9 < x + 4 < 12$$

Write down the two possible values of x .

..... or [1]

7 Here are the equations of some straight-line graphs.

$$y = 2x + 3$$

$$y = -2x$$

$$y = 2x$$

$$y = -2x + 5$$

Write each equation in the correct place in the table.
One has been done for you.

	Gradient is positive	Gradient is negative
Passes through (0, 0)		
Does not pass through (0, 0)	$y = 2x + 3$	

[1]

8 Find the 5th term for each of the sequences in the table.

n th term rule	5th term
$\frac{n}{4}$	
$n^2 - 11$	
n^3	

[2]

9 The diagram shows the positions of points A , B , C and D .

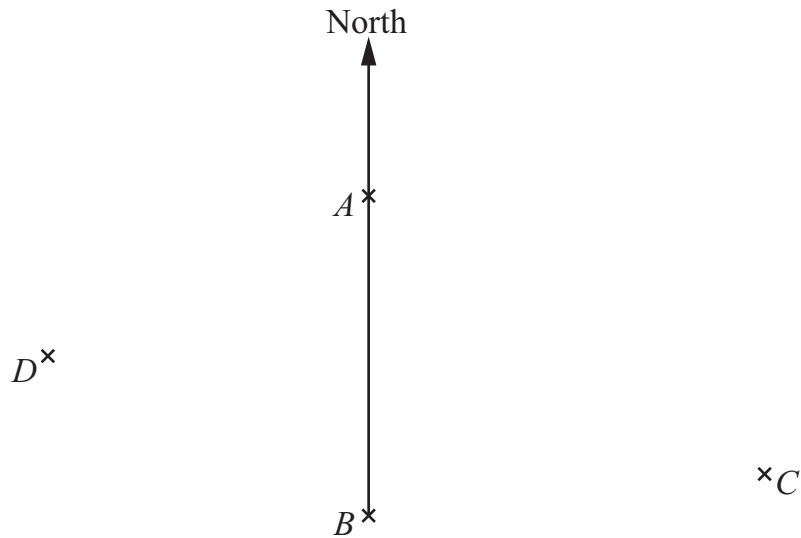

Draw a line to join each bearing to the correct description.

Bearing of B from A	Less than 180°
Bearing of C from B	180°
Bearing of D from B	More than 180°

[1]

10 Write a number in each box to complete the calculation.

$$3.5 \div \frac{7}{8} = \frac{\boxed{}}{2} \times \frac{\boxed{}}{7} = \boxed{}$$

[1]

11 The data shows the marks scored by students in a test.

45	46	47	49	50	50	52	53
54	55	56	57	57	58	59	59
61	62	64	65	66	72	73	74

Jamila records the test marks in this table.

Test mark	Frequency
20–39	0
40–59	16
60–79	8
80–99	0

(a) Explain why the class intervals chosen by Jamila are **not** the most appropriate.

.....
 [1]

(b) Complete the frequency table to record the data using more appropriate class intervals.
 You should choose class intervals with equal widths.
 You may not need all the rows in the table.

Test mark	Frequency

[2]

12 Simplify.

$$(a^3)^4$$

.....

$$\frac{4n+6}{2}$$

.....

[2]

13 (a) Write 50 000 in standard form.

..... [1]

(b) Write 4.07×10^{-3} as an ordinary number.

..... [1]

14 The counters in a bag are either red or blue or green or yellow.

A counter is picked at random from the bag.

The table shows the probability of some of the outcomes.

Colour of counter	Red	Blue	Green	Yellow
Probability	0.15	0.05	0.35	

Find the probability that the counter is red or yellow.

..... [2]

15 The diagram shows a circle with a horizontal diameter and a vertical diameter drawn.

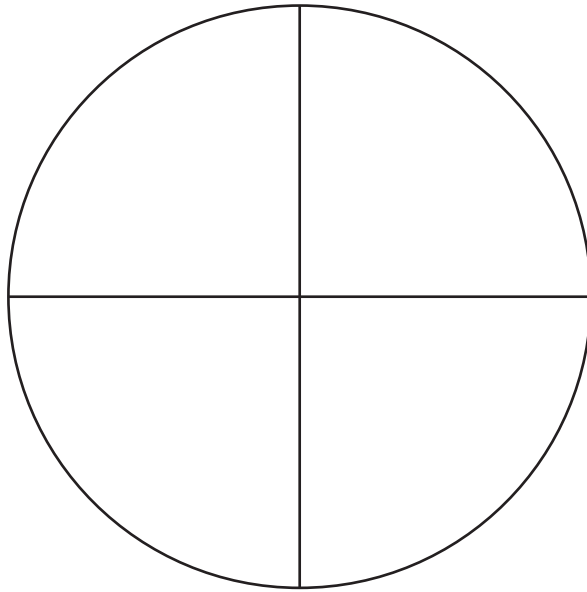

Use the diagram to construct an inscribed regular octagon.
Do not rub out your construction arcs.

[2]

16 Naomi measures the mass of each of 50 bananas.

Mass, m (grams)	Frequency
$100 \leq m < 110$	12
$110 \leq m < 120$	15
$120 \leq m < 130$	17
$130 \leq m < 140$	4
$140 \leq m < 150$	2

(a) Draw a frequency polygon to show this information.

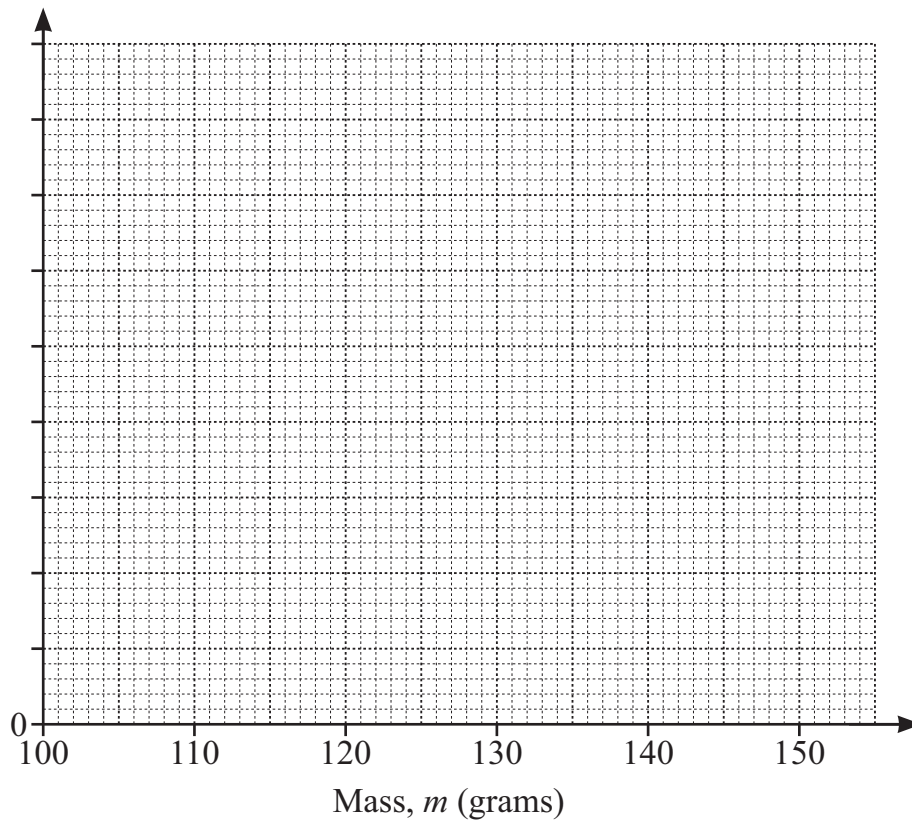

[3]

(b) Draw a ring around the class interval that contains the median mass.

$$100 \leq m < 110$$

$$110 \leq m < 120$$

$$120 \leq m < 130$$

$$130 \leq m < 140$$

[1]

17 Find the value of

$$10^3 \times 29 \times 10^{-3}$$

..... [1]

18 The values of a , b and c are $a = 10$ $b = 7$ $c = 4$

Tick (\checkmark) to show if the value of each of these expressions is equal to 64 or **not** equal to 64

	Equal to 64	Not equal to 64
$6(a + c)$	<input type="checkbox"/>	<input type="checkbox"/>
$\frac{a^2 + 28}{2}$	<input type="checkbox"/>	<input type="checkbox"/>
$(6 - 2b)^2$	<input type="checkbox"/>	<input type="checkbox"/>
$b^2 + c^2 - 1$	<input type="checkbox"/>	<input type="checkbox"/>

[2]

19 Calculate.

$$3\frac{1}{4} - \left(1\frac{1}{2} + 1\frac{1}{3}\right)$$

..... [3]

20 Write the correct power in each box.

$$6^5 \times 6^{-1} = 6 \square$$

$$8^4 \div 8^{-2} = 8 \square$$

$$\frac{1}{81} = 9 \square$$

[2]

- 21 BCD and EFG are parallel lines.
 $ACFH$ is a straight line.

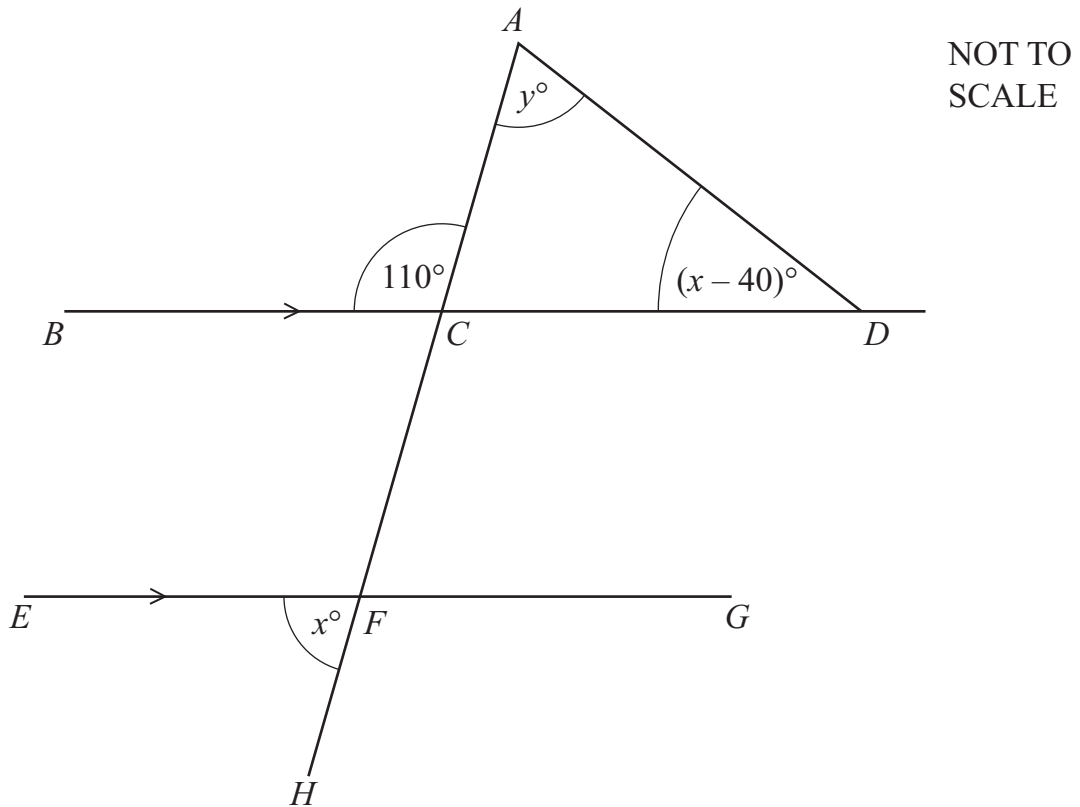

Calculate the value of y .

$y = \dots\dots\dots [2]$

22 Triangle J is shown on the grid.

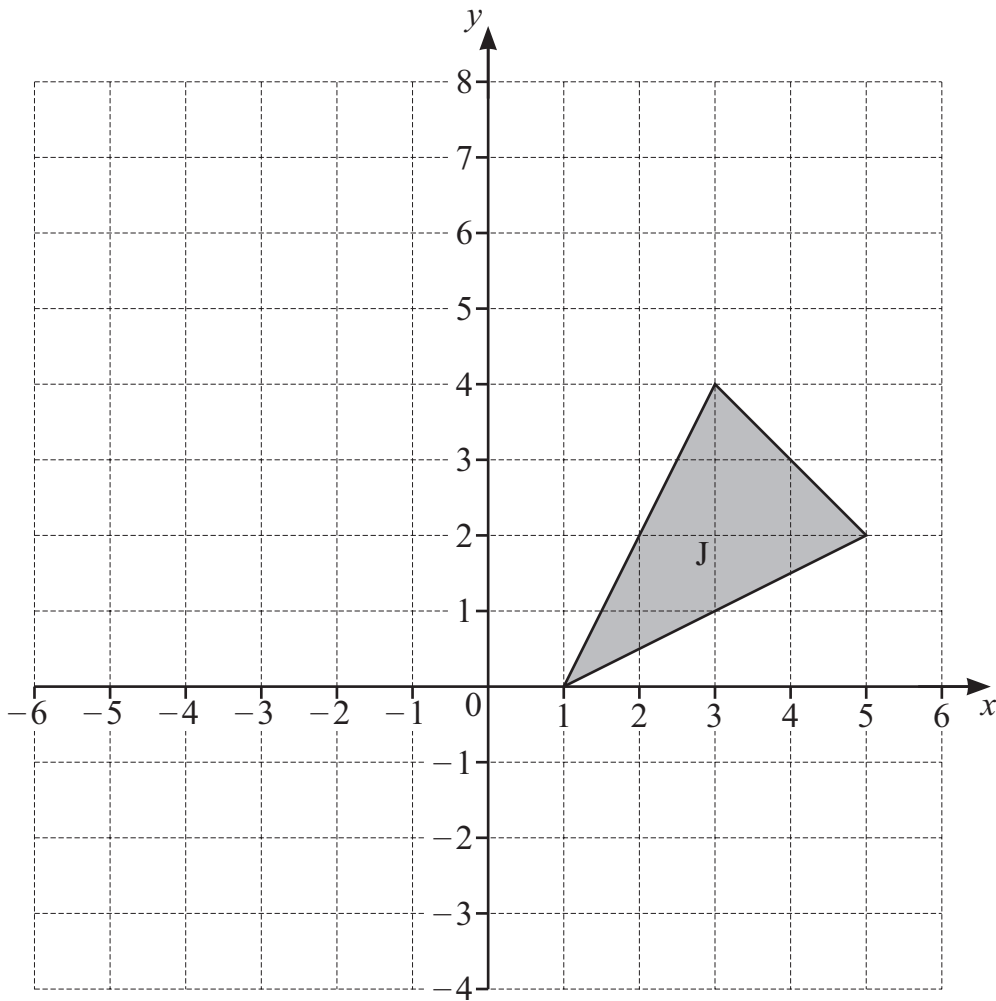

Triangle J is reflected in the line $y = 3$ to give triangle K.

Triangle K is then rotated by 90° anticlockwise, centre $(0, 2)$, to give triangle L.

Draw and label triangle L on the grid.

[2]

23 Tick (\checkmark) to show if each statement is true or false.

	True	False
$2 + 3 \times \sqrt{36} = 30$	<input type="checkbox"/>	<input type="checkbox"/>
$\sqrt[3]{8 \times 3 + 3} = 9$	<input type="checkbox"/>	<input type="checkbox"/>

[1]

24 The diagram shows the graph of the line $2x + 3y = k$.

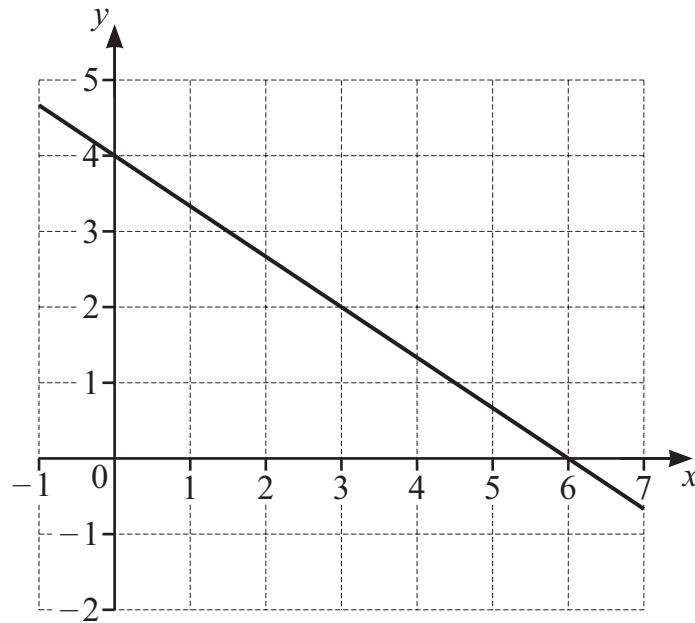

Draw a ring around the value of k .

4

6

12

24

[1]

25 Calculate.

$$\frac{0.8^2 - 0.01}{-0.09}$$

..... [3]

26 The values of x and y satisfy these simultaneous equations.

$$y = 4x - 2$$

$$3y = 7x + 14$$

Find the value of $2x - y$.

..... [4]

- 27 Chen and Hassan each play a game.
They can each either win or lose or draw the game.

Chen
Probability Chen wins is 0.3
Probability Chen draws is 0.1

Hassan
Probability Hassan wins is 0.5
Probability Hassan draws is 0.2

The outcome of Chen's game is independent of the outcome of Hassan's game.

Find the probability that Chen and Hassan **both** lose their games.

..... [2]

Permission to reproduce items where third-party owned material protected by copyright is included has been sought and cleared where possible. Every reasonable effort has been made by the publisher (UCLES) to trace copyright holders, but if any items requiring clearance have unwittingly been included, the publisher will be pleased to make amends at the earliest possible opportunity.

To avoid the issue of disclosure of answer-related information to candidates, all copyright acknowledgements are reproduced online in the Cambridge Assessment International Education Copyright Acknowledgements Booklet. This is produced annually and is available to download at <https://lowersecondary.cambridgeinternational.org/>

Cambridge Assessment International Education is part of Cambridge Assessment. Cambridge Assessment is the brand name of the University of Cambridge Local Examinations Syndicate (UCLES), which is a department of the University of Cambridge.